



 Liftec

NT Liftec Oy

New SC-30 industrial straddle carrier

14.10.2021

NT Liftec Oy – SC-30 straddle carrier



- Modern and effective straddle carrier for steel industry
- Designed for 24/7 operation
- Replacement for old Valmet / Bofors straddle carriers



NT Liftec Oy – SC-30 straddle carrier



■ Engine

- 2 x Deutz TCD 4.1
 - 115 kW, 610 Nm @ 1600 rpm
- Emission class: EU Stage IV / US EPA Tier 4
 - Through the use of the DPF (Diesel particulate filter), engines already comply with the EU Stage V emissions standard
- Possible to drive with one engine in emergency case

■ Transmission

- Hydrostatic transmission (Rexroth)
- Rear wheel drive

■ Working hydraulics

- Hydraulic steering / lifting / suspension



SC-30 straddle carrier

Capacity

- Lifting capacity: 32500 kg
- Lifting stroke: 1600 mm
- Transport speed (to both directions):
 - With full load: 20-22 km/h
 - Without load: 25 km/h

Main dimensions

- Cargo space (WxH): 2005 x 2800 mm
 - Wider and narrower constructions available
- Total width: 3450 mm
- Total height: 4810 mm
- Dead weight: 26 000 kg

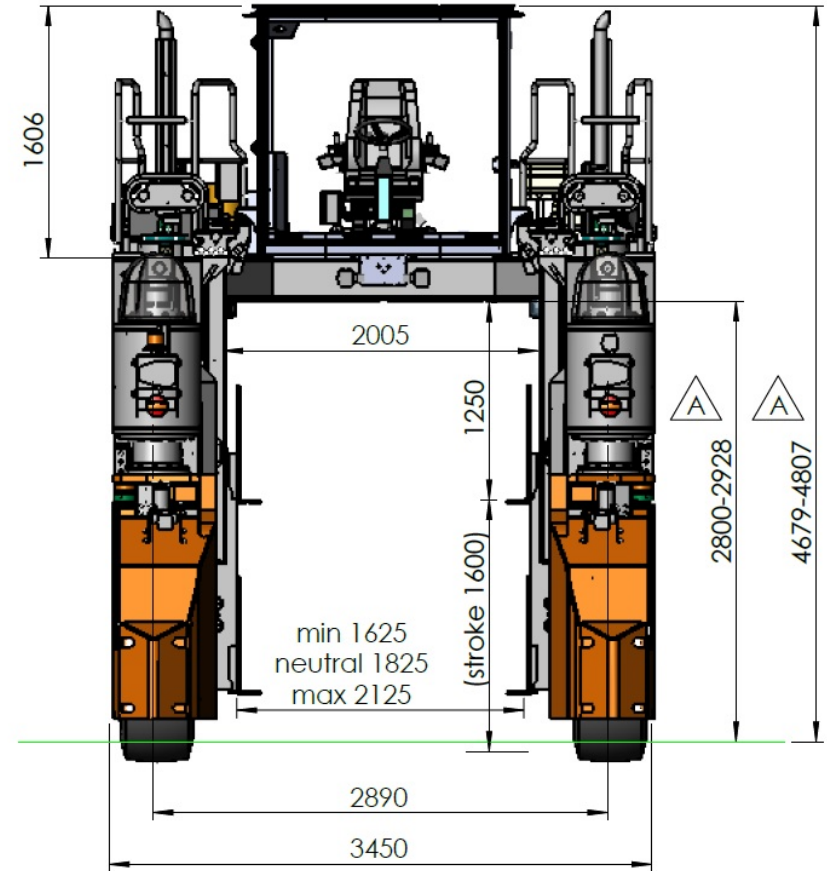

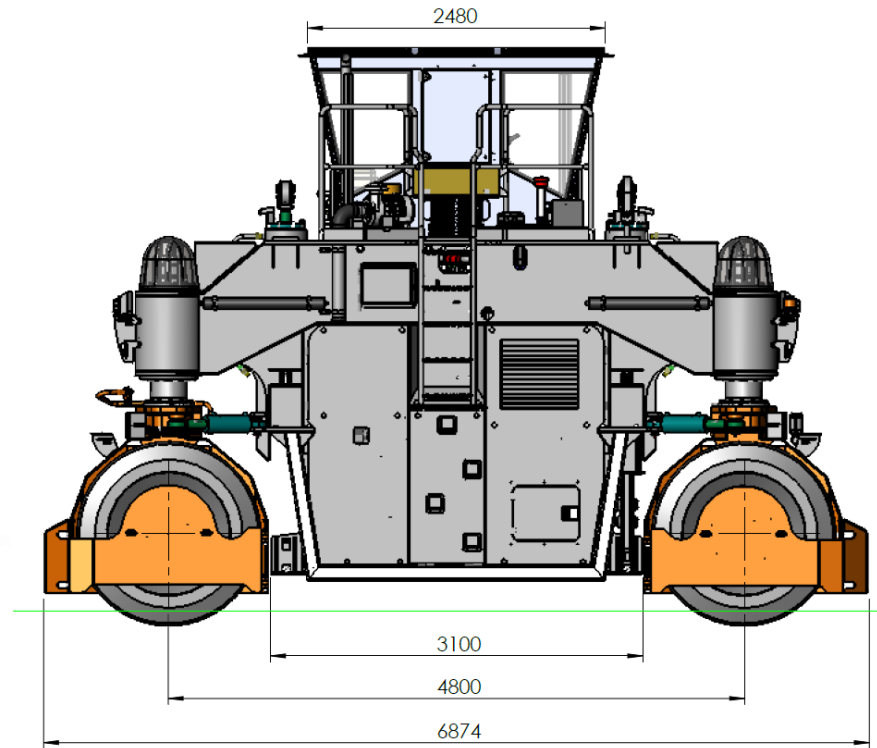
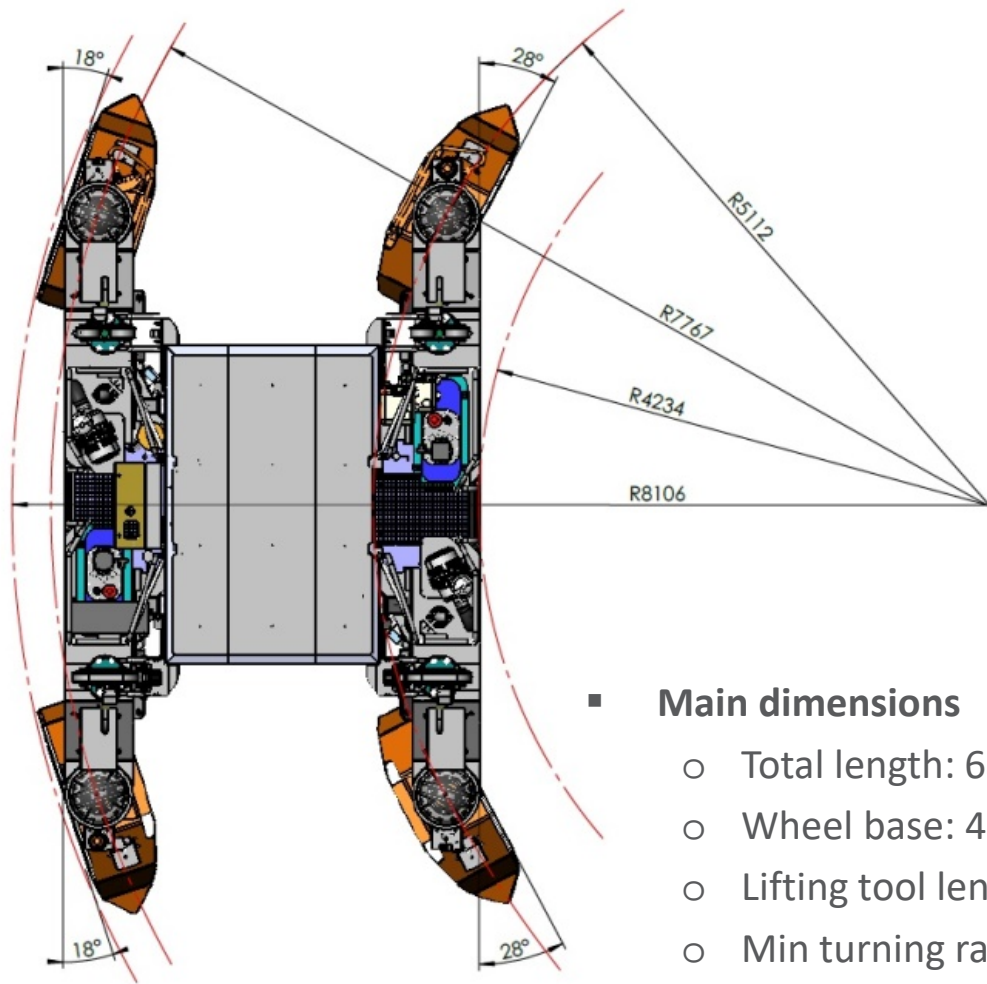

■ **Main dimensions**

- Total length: 6874 mm
- Wheel base: 4800 mm
- Lifting tool length: 3100 mm
- Min turning radius: $R=8106/4234$ mm

NT Liftec Oy – SC-30 straddle carrier



RIGHT SIDE

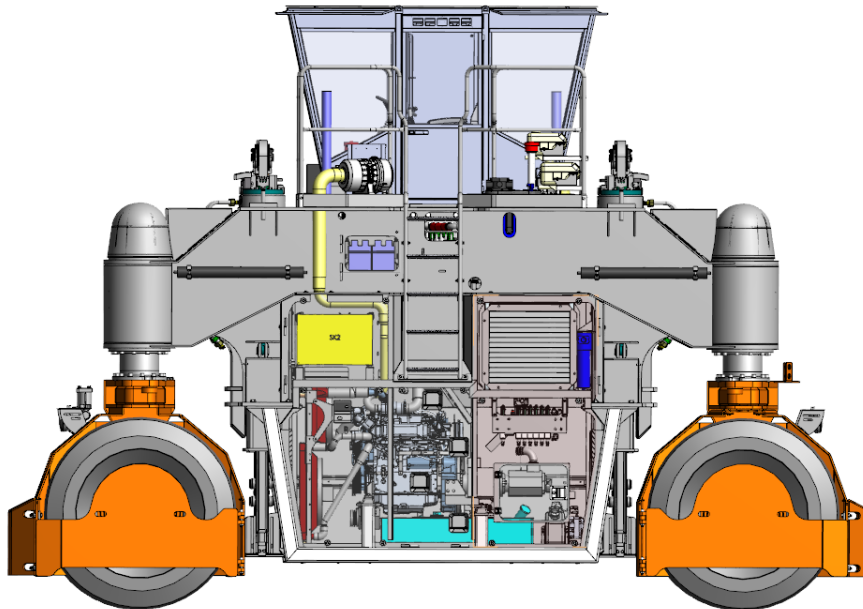

LEFT SIDE

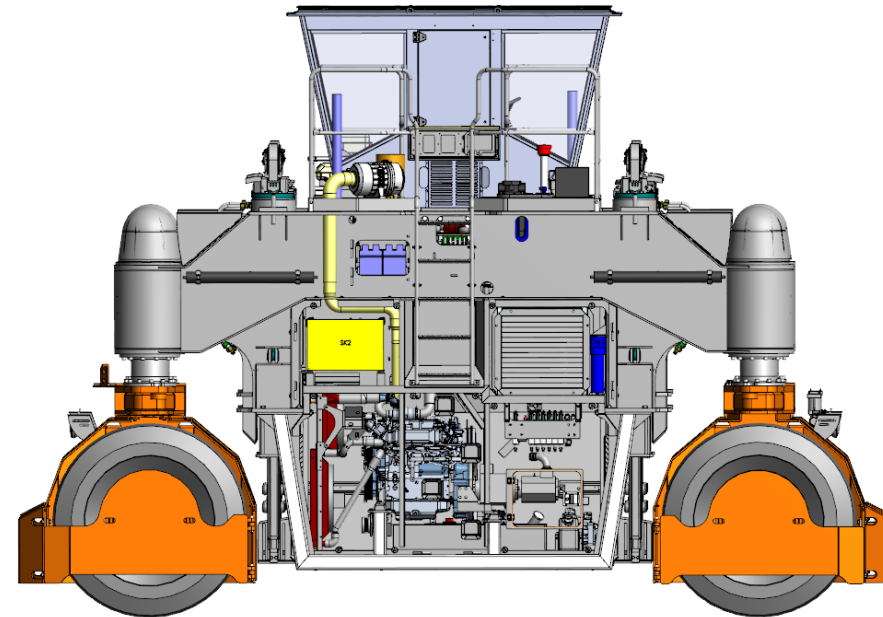

SC-30 straddle carrier

- **Electrics**
 - 24 VDC
 - CAN bus control system
 - Display for diagnostics and fault finding

- **Comfortable cabin with**
 - Excellent visibility
 - Low noise level
 - 180 degrees turning seat with electrical rotation
 - Joystick and steering wheel for steering
 - Air conditioning, radio etc.



NT Liftec Oy – SC-30 straddle carrier



■ References

- First delivery in 2006
- Used in 5 different steel mills in Sweden
 - Outokumpu Stainless AB (Avesta)
 - Ovako Bar AB (Boxholm)
 - Ovako Sweden AB (Hofors & Hällefors)
 - Sandvik AB (Sandviken)
- 18 machines delivered so far and oldest unit in operation has almost 30 000 running hours





Your logistics solution provider

NT Liftec is committed to provide the most cost-efficient transportation systems for ports, terminals and a wide range of industries. We are a development-oriented company driven by customer needs, offering systems and services that are designed to maximize the profitability of our customers' and cargo owners' business.



www.ntliftec.com