

QUALITY ON TIME

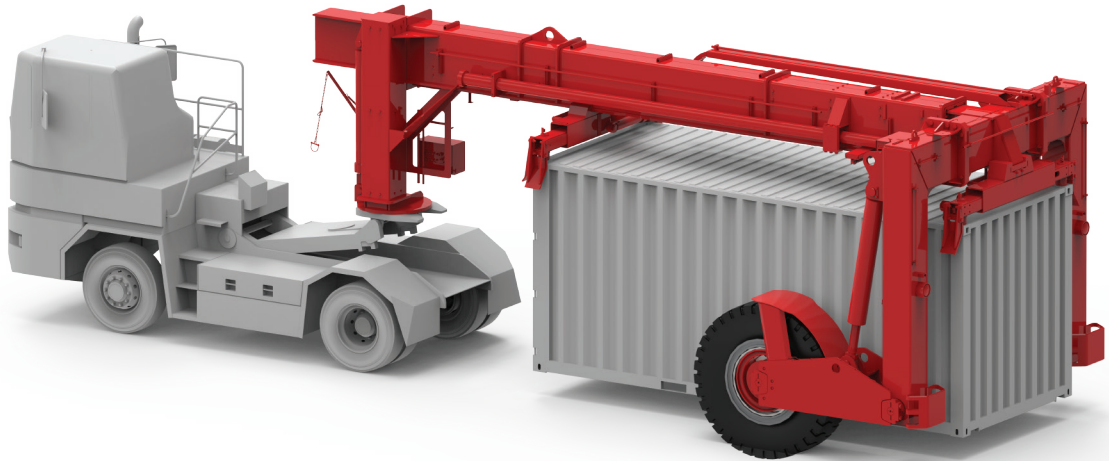

Container Mover



What we say, is what we do!

Introduction

The Container Mover is designed to handle containers at ports, terminals and other industrial areas. The compact design enables container handling in narrow warehouses and through low gates. The Container Mover is capable of loading and unloading 20-45 ft. containers up to 36-ton from road and terminal trailers. Low center of gravity of the container ensures easy maneuverability at longer driving distances with high speed. The Container Mover can be operated by one operator and a terminal tractor.

Telescopic Function

20 - 45 ft. Containers

Hydraulic telescopic function enables the Container Mover to handle containers from 20 - 45 ft.

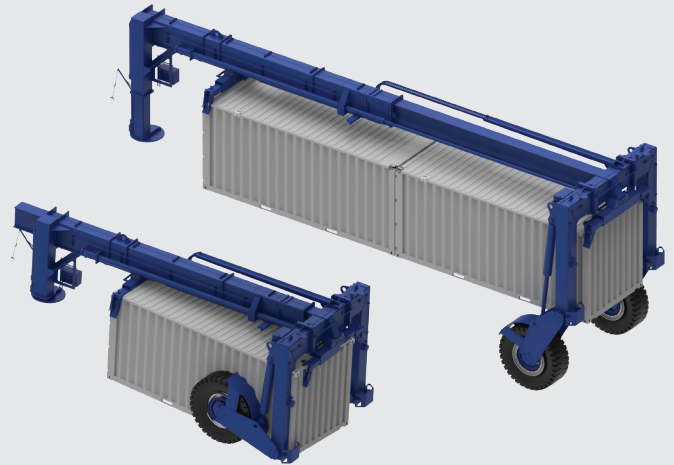

Lifting

- 2050 mm lifting height enables the Container Mover to lift containers on road and terminal trailers.
- ± 200 mm side shift for positioning of twist lock grippers, guided by sensors, enables pick up and lowering of unaligned containers.
- 4 x ultrasonic sensors ensure even lifting of containers.

36.000 kg



Dimensions

Standard min driving height 3830 mm
(Optional 3780 mm)

Compact design enables container handling in low and narrow warehouses

Total max length	15500 mm
Total min length	9865 mm
Total width	4221 mm
Total max height	5830 mm
Total min height	3730 mm
Width of cargo space	2900 mm

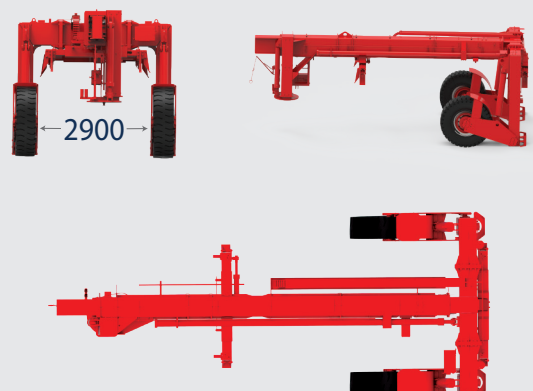

Operation

- Fully operational from tractor
- All function operated from joystick, remote or tablet
- Wide angle and rear view cameras
- Monitor with camera view (optional)
- LED rear and brake light combined with turning signals
- 6 x LED working lights
- Reversing alarm
- Parking on parking stand or container
- Emergency lowering of container

Technical Details

Load	36.000 kg
Weight	18000 kg
Driving speed	20 – 40 km/h
Lifting height	2.050 mm
Pneumatic tyres	18.00-25 PR40
Wheel Capacity	21.200 kg
Operating hydraulic pressure	180 bar
Max hydraulic flow	130 l/min
Operating voltage	24 VDC

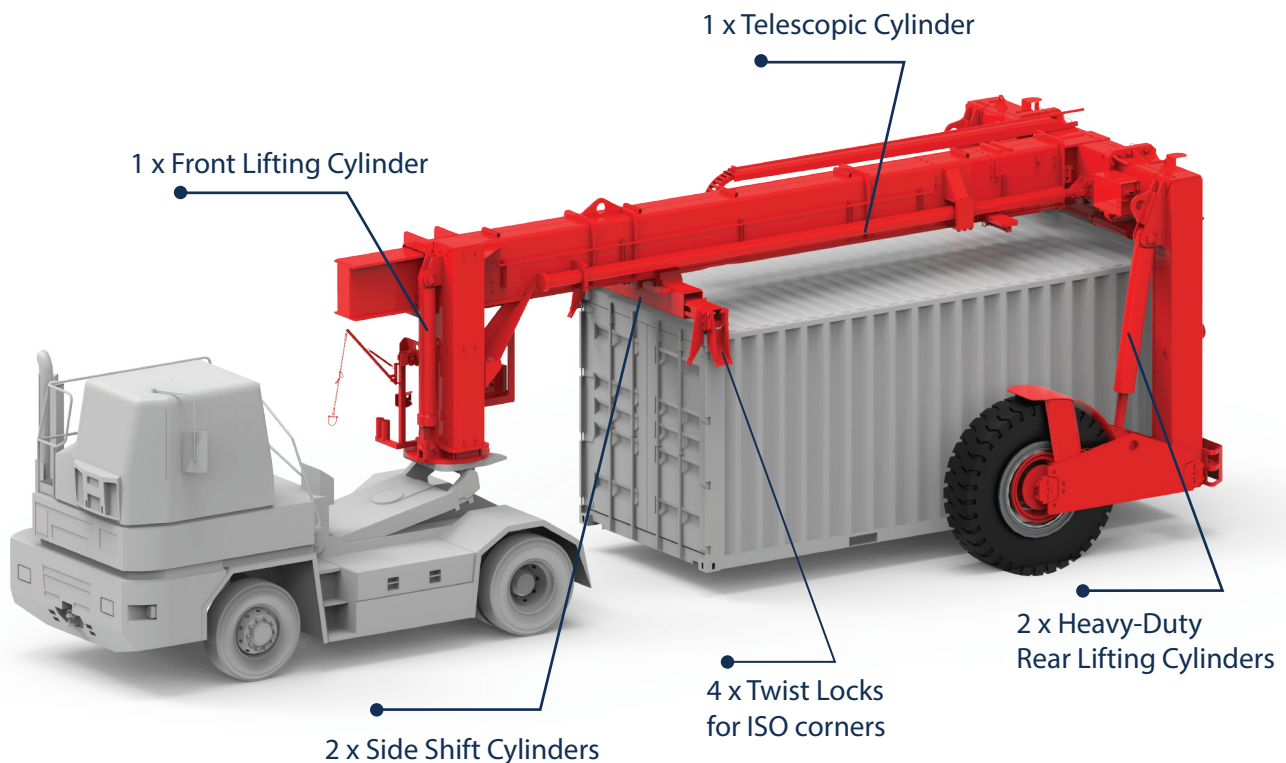

Options

- Disc brakes with one or two calipers on each wheel
- Central lubrication system
- 45 ft containers. (Depending on container design)
- Monitor for camera view

Road Truck Version

The Container Mover can be adapted for Road Trucks





 What we say, is what we do!

www.ntgroup.com



(+358) 3 3140 1400
(+45) 98 16 50 09



sales@ntliftec.com
mail@novatech.dk

